

TWISTER 3.1

Two-way horn loaded passive system

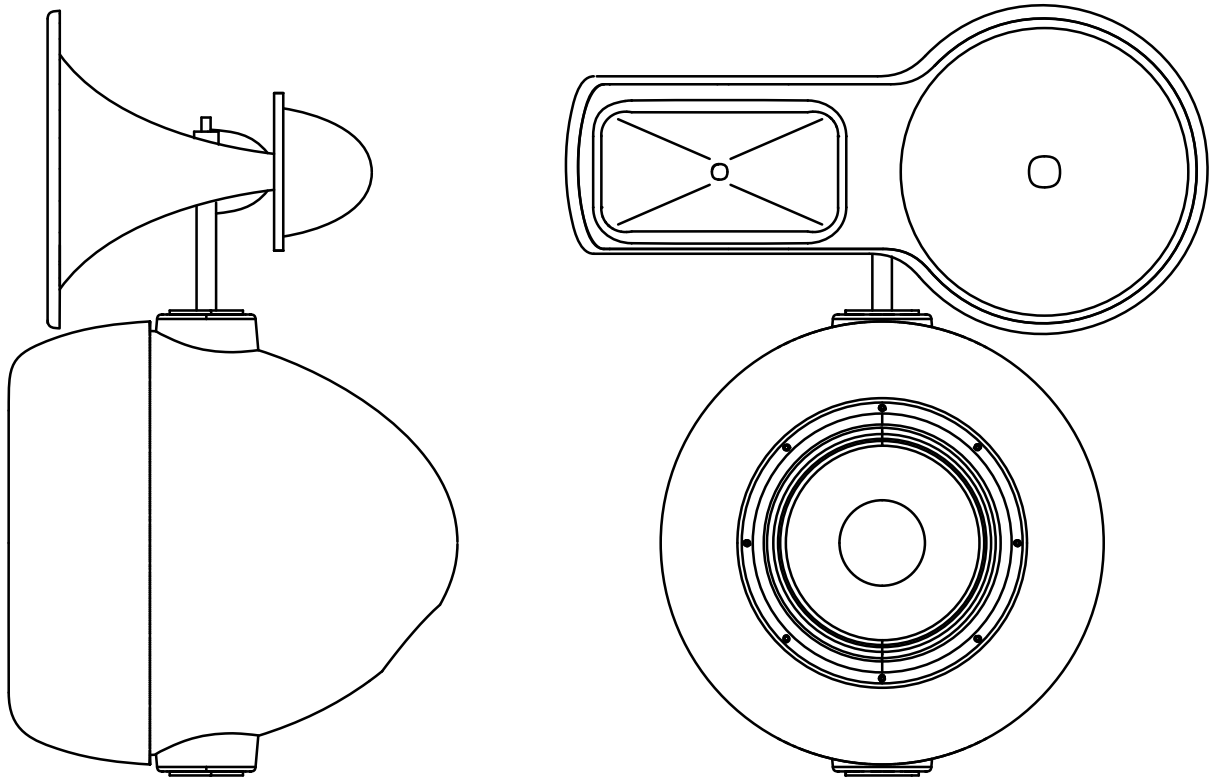

User guide

TWISTER 3.1

Two-way horn loaded passive system

Index

- 1 Technical Specifications
- 2 Unpacking and Checking
- 3 Cables and Set-up
- 4 Installation and System Design
- 5 Accessories
- 6 Maintenance and Surface Protection
- 7 Warranty
- 8 Authenticity

1 Technical Specifications

USER GUIDE

EF5 Twister 3.1 is a passive 3-way horn-loaded system with an extended low-frequency direct emission component. Professional HI-PRO two-way audio system with horn-loaded speaker technology, designed to seamlessly integrate with dedicated transducers, built from high resistance composite materials for elevated sensitivity, dynamics, and definition. Wide-angle coverage of a highly controlled sound field, and the ability to reach high sound levels without perceptible distortion. The system is characterized by excellent sound quality the ability to reach high-pressure ranges. A pair of large full-frontal horns manage the high-mid frequency range through a dedicated passive crossover (or using a 2 ch amplifier+DSP). The high-range horn is characterized by a special high-end derivation design. The long and complex development with variable sections allows a wide dispersion with powerful loading. The Shockwave 2.1 mid-range horn has a unique design that creates an extraordinary level of efficiency and sensitivity. This allows for excellent dynamics that distinguish the entire system from the very first listen. The extended low-frequency direct emission component is characterized by a light structure with a highly resistant ovoid shell, containing a 15 "woofer with a 30-400 Hz range and high sensitivity. This component can alone cover the mid and low frequencies or can be assisted by additional subwoofers to cover the lower frequencies with additional power. The LF driver features a water-resistant cone. Components such as the speakers, woofers, and compression drivers all represent world-class quality, without commercial technological compromises. Thanks to its elevated sensitivity, the system requires limited amplification power. The EF5 Twister system is manageable through bi-amplification with DSP for managing cuts between the high-mid and low routes. The two high-mid horn components are managed passively by a specific crossover filter. A Full-Fat audio FFA 8004 is the recommended 4 channel amplifier partnered in this system (stereo configuration) with a dedicated DSP. Otherwise, it can be managed actively by three amplifiers and by traditional DSP. Any additional subwoofers are sold separately.

TYPE	Two ways passive full-horn loaded with extended low frequencies direct emission component
FREQUENCY RESPONSE	40 Hz - 18 KHz
TOTAL SENSITIVITY	109 dB 1W/m with passive crossover for mid-high component 97 dB 1W/m for low component
LOW FREQUENCY	15" Low woofer 8 Ohm 1000 W nominal 2000 W peak
MEDIUM FREQUENCY	2" (50 mm) MF compression driver 8 Ohm 80 W nominal 160 W peak
HIGH FREQUENCY	1" (25 mm) HF compression driver 8 Ohm 60 W nominal 120 W peak
NOMINAL IMPEDANCE	4 Ohm with two way passive crossover for mid-high component 8 Ohm for low component
CONTINUOUS POWER HANDLING	400 W 4 Ohm for mid high frequencies 2000 W 4 Ohm for low frequencies
MANAGE	4 Ch amplifier to a couple of Twister loudspeakers (outer passive crossover provided, for each Twister horn loaded mid+hf)+DSP . Horn loaded mid+hf :High-pass filter @400Hz, 24 dB/oct. LR;Relative Gain -12dB,Delay 0 ms 15": High-pass filter @40Hz, 24 dB/oct.But, Low pass filter @400Hz, 24 dB/oct. LR
RECOMMENDED AMPLIFIER	Full Fatt Audio FFA 8004 with crossover with DSP
DISPERSION	60° horizontal, 40° vertical
CONSTRUCTION MATERIALS	Fiber-reinforced composite, stainless steel
FINISH	all ral color and texture on order
PROTECTIVE GRILLES	Twister is usually sold with this grid made of stainless steel
CONNECTORS	3x Neutrik NL4 or custom preference
DIMENSIONS (with trolley)	(W) 1100 mm (H) 950 mm (D) 700 mm (W) 42 inch (H) 37 inch (D) 28 inch
WEIGHT	14 Kg (31 lb) mid-high component, 22 Kg (48 lb) low component

2: Unpacking

The Twister, like every other Pequod product, is built with high standards of control and quality. At the end of the production process and before packaging, each system is tested: acoustically measured and recorded in our company database. For each Twister serial number, we have the related test files recorded in the archive. Before being packed in its box we complete an inspection of surfaces and structures. Units are packed into wooden crates or heavy cardboard boxes with internal foam padding before shipping.

Extraction from box:

The Twister 14 Kg (31 lb) mid-high component, 22 Kg (48 lb) low component each, and it's being shipped contained inside suitable wooden packaging box. Its extraction from the box is achievable by two operators, at least.

Notes: Twister is coded in 2 versions mirrored, right and left (cod Right and cod Left), for stereo configuration

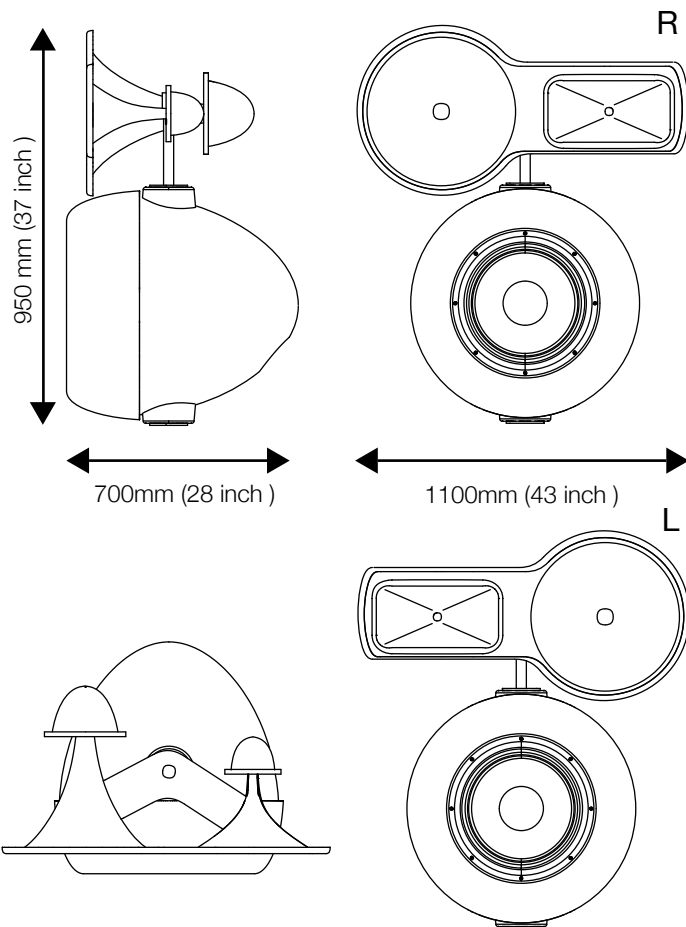

USER GUIDE

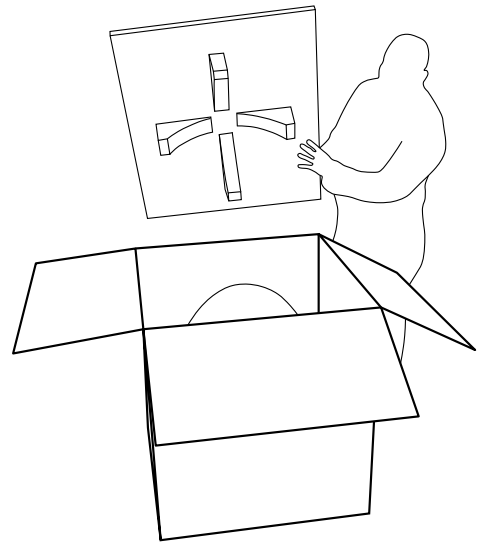

1: Remove packing materials and save for re-use

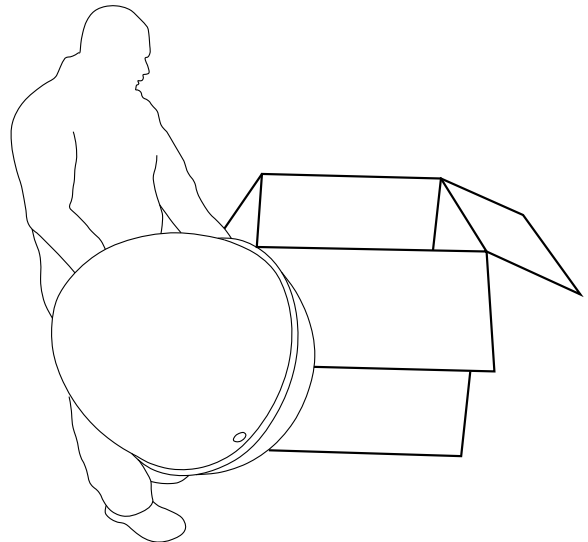

2: lift speaker body with both hands when ready

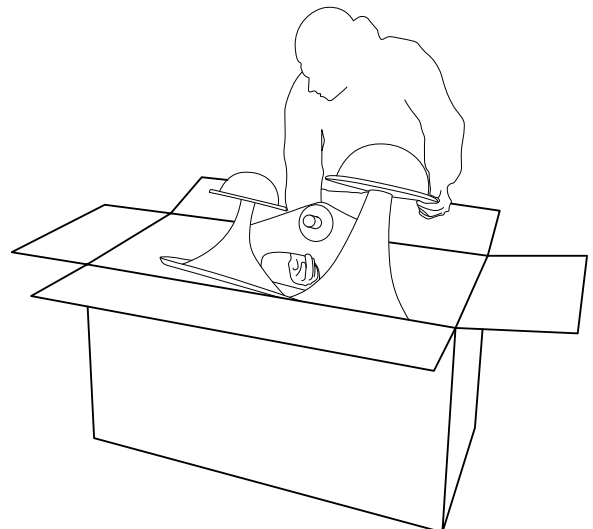

The SW has 3 inputs made with a female NL4 connector. The mid + hf part is connected to the crossover (contained in a crossover box of 3 types: wp box in composite, standard box, metal rack box put the codes) via a Y cable (if purchased from Pequod it is the code CAB03TWI) thus made: 2 2-pole cables (minimum section 2.5 mm² per pole, for cable lengths up to 15m), terminated with 2 male connectors (A and B) NL4 (+ 1 / -1 connected, + 2 / -2 empty), merging into a single 4-pole cable (minimum section 2.5 mm² per pole) terminated with 1 male connector (C) NL4 (+ 1 / -1 connected, + 2 / -2 connected) See diagram below

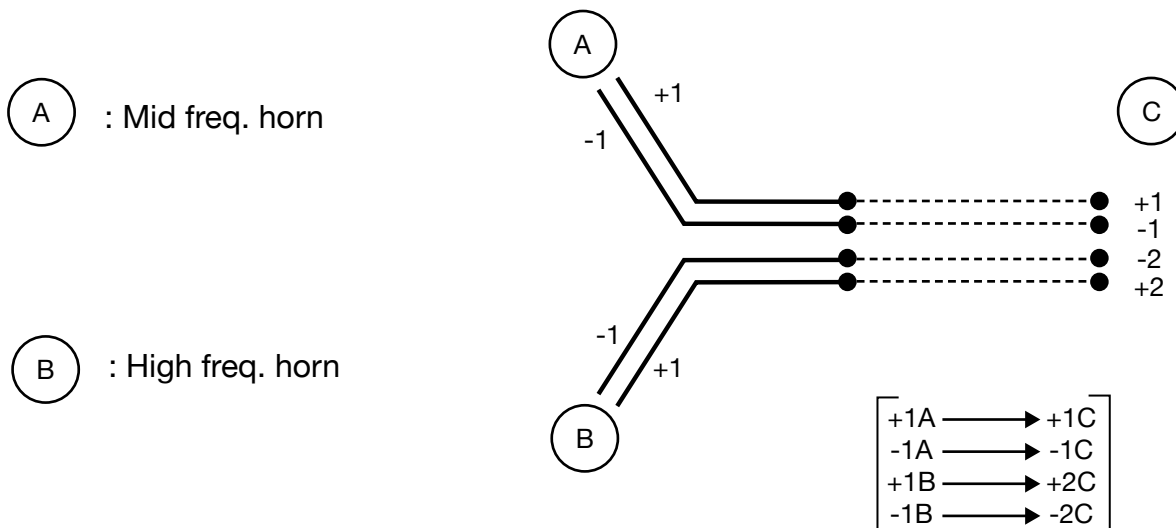
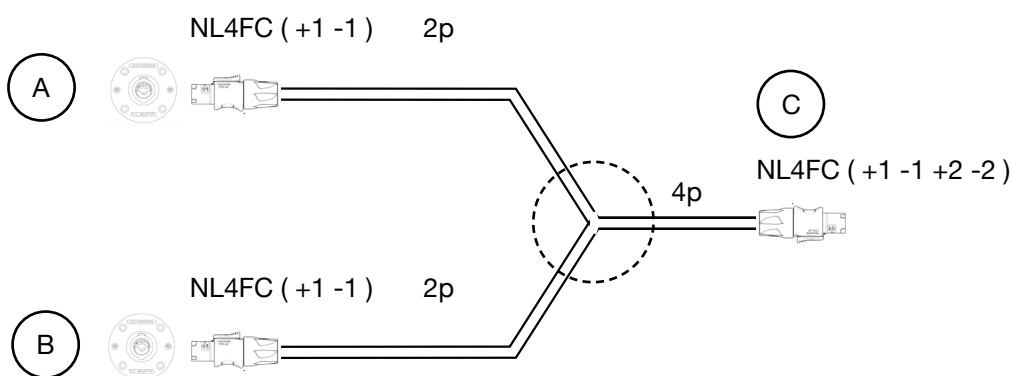

1) Cable between crossover and amp (not supplied): 2-pole cable (2.5 mmq minimum section per pole up to 15 m cable length, in addition we recommend switching to 4 mmq per pole), terminated with NL4Fc male connector (+ 1 / -1 connected and corresponding to +1 red and -1 black on the amplifier, + 2 / -2 empty) to connect at the crossover input, which has an NL4fc female connector, standard or WP on request.

2) Cable between Ovoid15 "and amp (not supplied):

as above In case of custom realization by the installer of the connection cables, we recommend specifying installation-grade Low Smoke Zero Halogen (LSZH) cables for permanent installations. The cables should use Oxygen Free Copper (OFC) of grade C11000 or above. For distances of more than 15 meters between xover and amplifiers we recommend increasing the section of the cable poles to 4 mmq, to avoid excessive emission level losses. For lengths of less than 15 m, you can use 2-pole cables, each with a section of 2.5 sq. Mm.

DSP general settings:

Horn loaded mid + hf: High-pass filter @ 400Hz, 24 dB / oct. LR; Relative Gain - 10dB, Delay 0 ms
 15 ": High-pass filter @ 40Hz, 24 dB / oct., Low pass filter @ 400Hz, 24 dB / oct. LR

If subwoofer is needed:

Horn loaded mid + hf: as above

15 ": High-pass filter @ 100Hz, 24 dB / oct., Low pass filter @ 400Hz, 24 dB / oct. LR

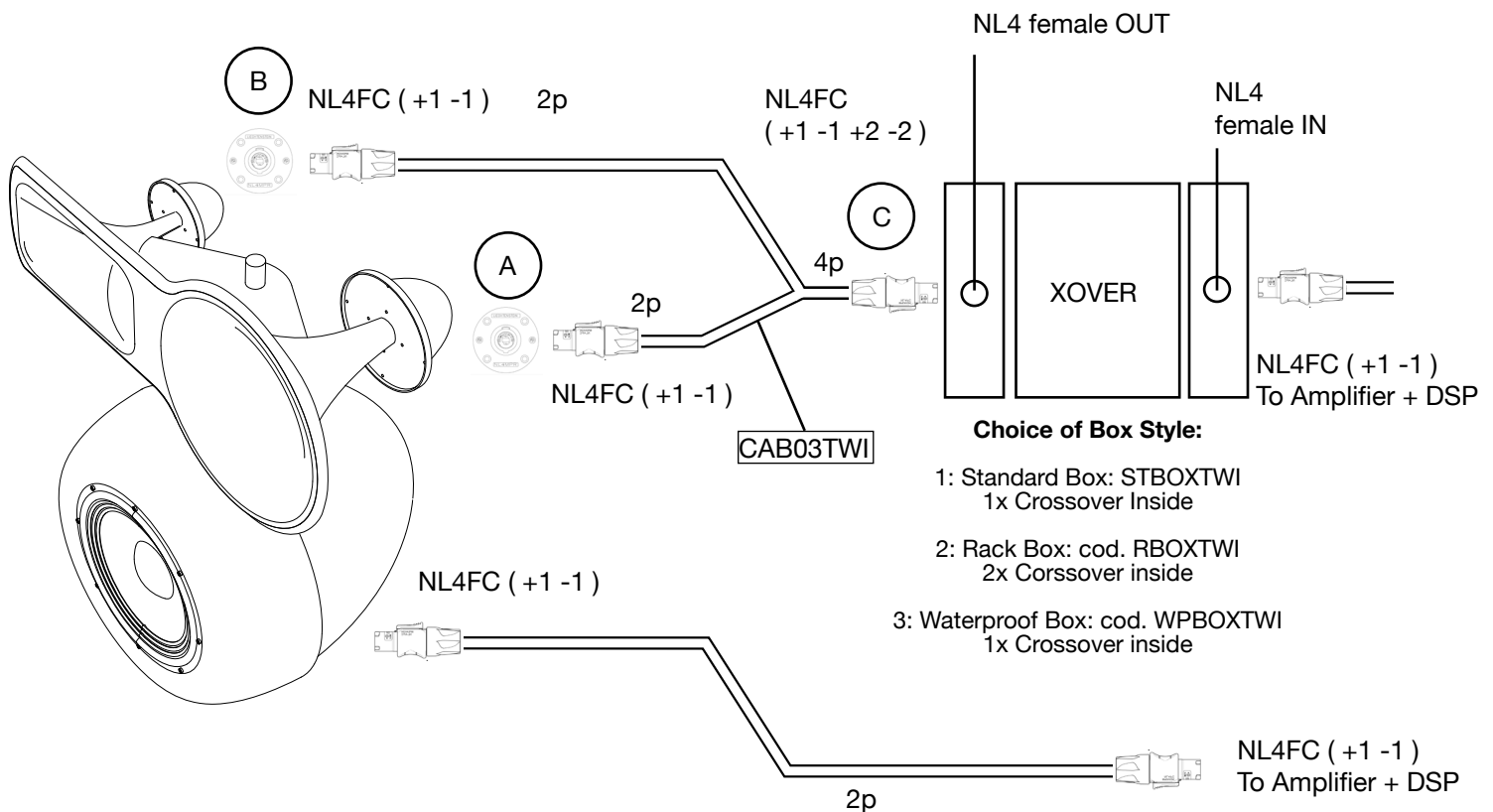

4 Installation and system design

Twisters can typically be used as a high quality system to sound areas of listening, like a dance floor or for a medium-sized audience of a live concert. In some cases it is necessary to use suitable subwoofers (Ovoid or Hydra available from the Pequod catalog) to have a full range system. For on stage installation facing an audience, they can be housed on their stand or, via tube on the subwoofer (like Ovoid18) for easy management and handling

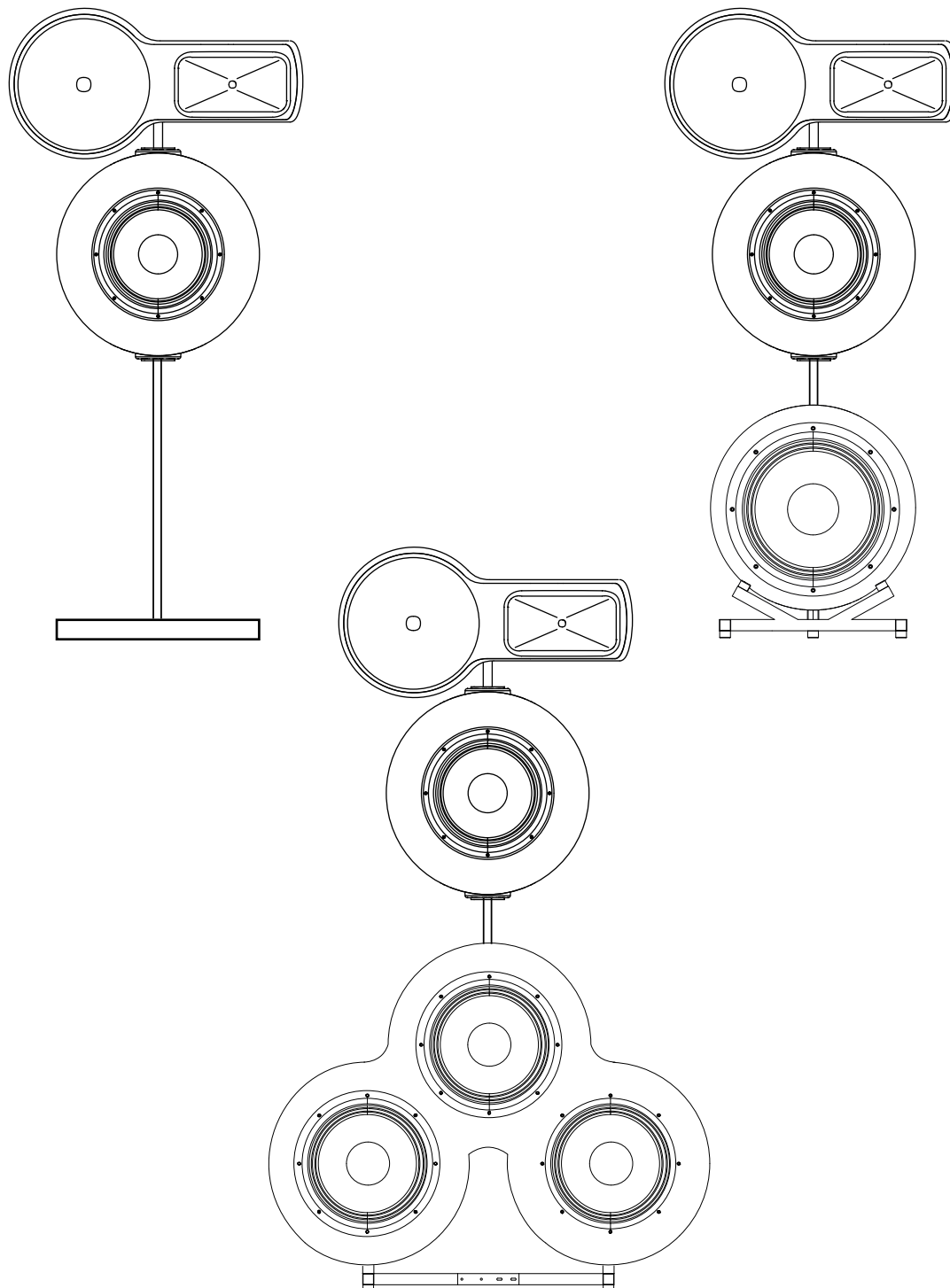

It should be borne in mind that optimal acoustic coverage is obtained by lifting the Twisters 2 -4 m from the ground on the vertical plane, tilting them towards the audience, so that the ideal outgoing axis between the HF and MF horns is oriented in an area placed between $1/2$ and $2/3$ of the depth of the area to be soundtracked (dance floor or stalls). On the horizontal plane, it is also necessary to orient the ideal axis coming out of the SWave in an area that is placed at about $2/3$ of the depth of the area to be soundtracked, on the center line of the area itself.

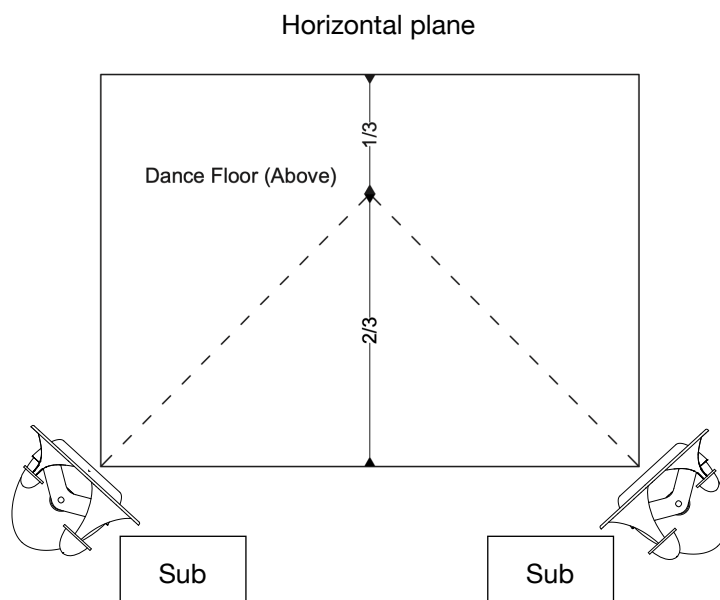
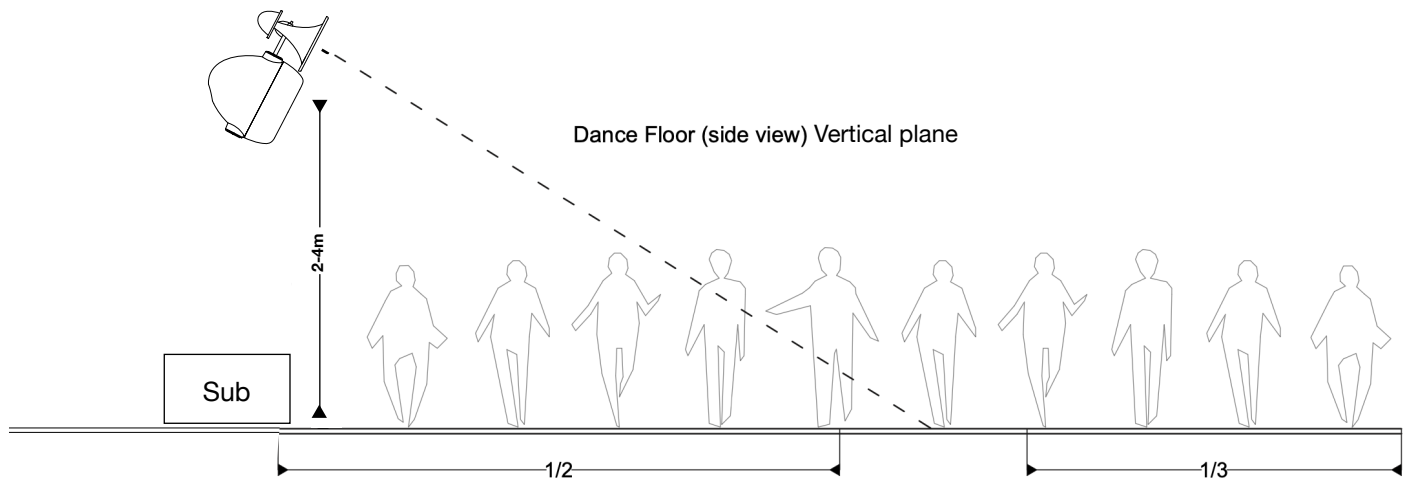

5: Accessories

In the Pequod catalog there are some accessories to be used with Twister.

Cod. BAG01TWI: Protective PVC Bag sized for Twister system, waterproof soft finish to protect from scratches and weather.

Cod. GROV: Front Protection Grille of the woofer, made of stainless steel. Usually included as standard component in most orders, delete options is available when protection is not needed.

Cod. BSSTTWI: stand with Concrete Base with logo and stainless steel 350mm tube for supporting a freestanding Twister system without Ovoid sub.

Cod. TBBOV18TWI: Ovoid Connection Pipe in stainless steel diameter 35mm, length 350mm suitable for coupling above the sub Ovoid 18 system. Other lengths available on demand.

USER GUIDE

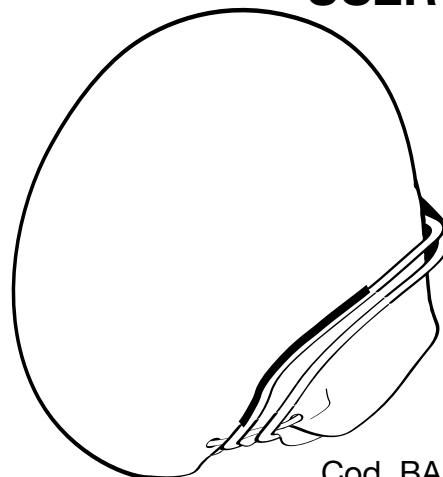

Cod. BAG01TWI:
Protective PVC Bag

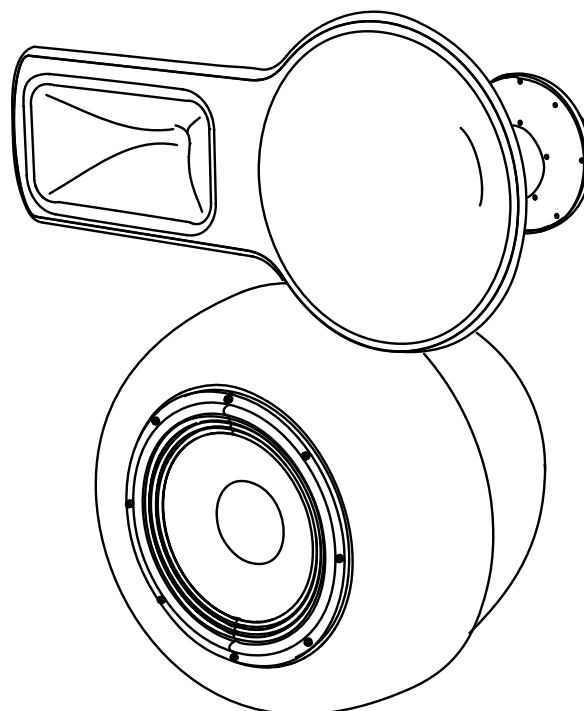

Cod. BSSTTWI:
stand with Concrete
Base

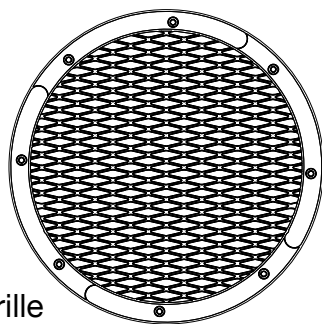

Cod. GROV:
Front Protection Grille

Cod. TBBOV18TWI:
Ovoid Connection Pipe



6: Maintenance and Surface Protection

All Pequod units are built from a unique high quality composite material which is inert to atmospheric agents and requires minimal regular maintenance, just a simple cleaning of the surfaces with a soft cloth dampened with alcohol.

For best practice in long term care of the composite components, and to obtain or restore a truly professional level of surface finish, we recommend using the 3M "Perfect It™" line of Gelcoat cleaners and protective waxes (above right).

Follow the instructions provided to ensure the best possible finish for your Pequod composite speaker bodies and accessories.

Warning: All Pequod products are polished by hand, by a specialized operator, one by one, before being packaged in their box.

Any traces or residues of wax (opaque white) may be present on the surfaces of the products. They are obviously easily removable with a soft cloth and in no case do they represent a qualitative defect, but rather evidence of a polishing process carried out by hand, with high quality waxes.

Many installations require Stainless Steel support structures or armatures to complete mounting and assembly of different Pequod units. For these components, we recommend cleaning with 3M™ Stainless Steel Cleaner and Polish (right).

USER GUIDE



Pequod Acoustics offers a guarantee to the original owner (person or company who purchased the product brand new) of each new Pequod product (provided it was purchased directly from Pequod or through a Pequod Acoustics Authorised Dealer/ Distributor) that it is free of defects in materials and workmanship and that each product was tested in the factory to meet or exceed all specifications declared. Each model has a test file recorded in our database, related to its serial number.

The period of limited warranty is three (3) years from the date of delivery to the original purchaser (as shown on the original invoice or sales receipt; a copy may be required as proof of warranty dates)

Pequod Acoustics will repair or replace (at its discretion) all defective parts at no charge for labor or materials; subject to following provisions:

Pequod Acoustics shall take no responsibility for repair or replacement under this warranty if:

- a) The damaged product has been subject to misuse, accident, neglect or failure to comply with normal maintenance procedures
- b) There are improper alterations or unauthorized parts or repairs.
- c) The serial number has been altered, defaced or removed and the original owner won't be able to give information related to our Anti-counterfeit authentication system (see below, section 8)

Pequod Acoustics will remedy any defect, regardless of the reason for failure (except as excluded above) by repair or replacement. Pequod Acoustics will ship the product within a reasonable time after receipt of the defective product at a Pequod Acoustics Authorised Service Centre.

How to obtain service under warranty:

If a Pequod Acoustics product requires service, the original owner must contact the Pequod Acoustics dealer who supplied the product, to receive our Return Authorisation Code (RA code), and instructions on how to return the product to the Pequod Authorised Service Centre, or to Pequod Acoustics.

The original owner must give information about:

- Problems with the product
- Serial number
- Original invoice or sales receipt
- Anti-counterfeit system (see section 8)

After receiving the RA code the owner can pack the unit in the original factory packaging if possible. Please include a note describing the problem packed together with the product. Do not send it separately.

All products being returned to the factory or service center for repairs must be shipped prepaid. Ensure safe transportation of your unit to the authorized service center

Pequod Acoustics (or an Authorised Service Centre) will initiate corrective repairs upon receipt of the returned product, in order to complete the repairs and ship back the product within a reasonable amount of time.

If the repairs made by Pequod or a Pequod Authorised Service Centre are not satisfactory to the owner, they are instructed to give written notice to Pequod.

The original owner is not entitled to recover from Pequod any incidental damages resulting from any defect in the Pequod product. This includes any damage to another product or products resulting from such a defect.

The warranty is not extended by the length of time which the owner is not engaged in active use of the product. Repairs and replacement parts provided pursuant to the warranty will be covered only by the non-expired portion of the warranty.

8: Authentication and Anti Counterfeiting Measures

USER GUIDE

Each product by Pequod Acoustics is carefully hand made using high quality components that are, by themselves, difficult to replicate. But we also protect our products using special marks on the inside and outside, which are unique and serve to authenticate original Pequod products.

Thus, each individual product has a special mark, placed in a unique position. For each product (each serial number) we keep a record of the exact position where we placed this mark.

When warranty claims are made, or other requests that require authentication of an individual Pequod product, we will ask the owner to provide a description of the identifying marker as further proof of originality.